



**COREAL MACHINERY**

# **Rotary Vibrating Screen**

**General screening equipment**



# Rotary Vibrating Screen

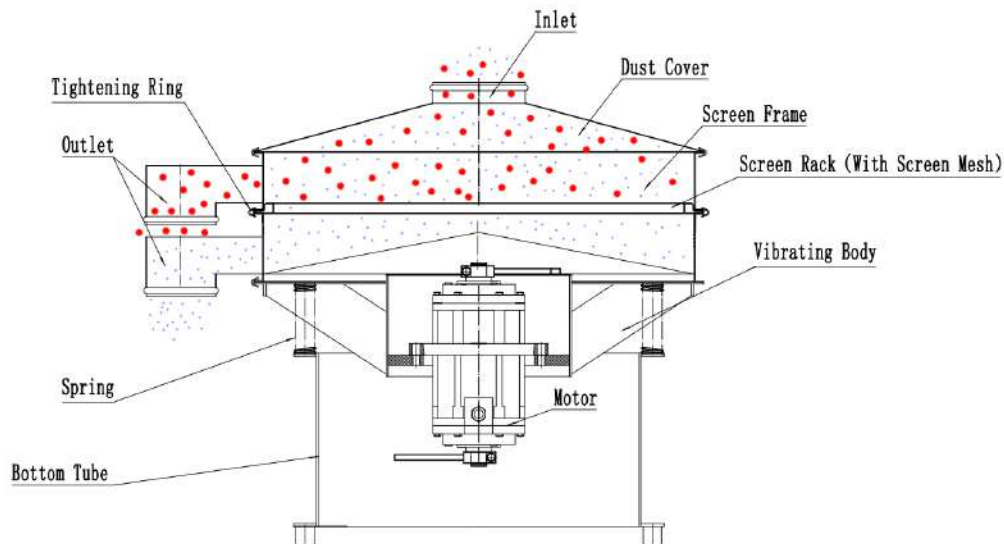

**Rotary Vibrating Screens** are used to separate particles by size or to separate solids and liquids.

Designed for maximum screening efficiency, they can be built and finished to food, dairy and pharmaceutical standards.

This type of vibrating screen is widely used and very common.

Discover **all** its features.

# Economical & Efficient



- Advantages:**
- Widely used
  - High screening efficiency
  - Low maintenance cost
  - 1-5 layers available
  - Ultrasonic system optional
  - Support customization

Details that make the difference

# Various Designs



- The sieve body is made of stainless steel (SUS304 or 316L)
- Conforms to food grade or medical grade
- Meet high standards

Details that make the difference

# Various Designs



- Optional rotating brush (for materials that are difficult to screen with ordinary screening)

Details that make the difference

# Various Designs



- The screen body can be made of polypropylene (PP)
- Has certain anti-corrosion properties
- Optional nylon screen mesh

Details that make the difference

# Various Designs



- Solve the screening of **ultra-fine powder** materials (the finest is 600 mesh [0.02mm])

- Use advanced ultrasonic system (optional)

## Ultrasonic frequency



35KHz ultrasonic vibration band

Features: high frequency, low amplitude

Applicable to: 200 mesh and finer screens

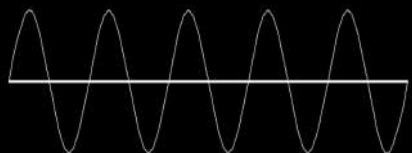

28KHz ultrasonic vibration band

Features: low frequency, high amplitude

Applicable to: 200 mesh or coarser screens

Details that **make the difference**

# Applied to These

**Powder, granules:** Screening, Grading, Impurity removal

**Ultrafine powder:** Screening, Grading

**Slurry:** Filtration

## Application



Food Industry



Pharmaceutical Industry



Additive Manufacturing



Chemical Industry

# Application



# Product Display



# Product Display



# Accessories

## Screen Mesh



## Spring



## Sealing strips



## Screen Grid



## Iron remover



## Bouncing Ball



# Accessories

## Soft connection



## Motor



## Ultrasonic system



## Other screening machine parts



# Selection Guide

## Common Size

Diameter	Layer
400mm	1-5
600mm	
800mm	
1000mm	
1200mm	
1500mm	
1800mm	
2000mm	



Provide us with specific technical requirements.

Customization is supported

**OR**

1. Material name
2. Screen hole (mm)
3. Production capacity requirement (Kg/h)

We will select or customize for you based on these information.

**MORE THAN A TECHNICAL SERVICE.  
WE ARE YOUR TEAM!**

## **CONTACT**

**Louis Lu**

河南科瑞尔机械设备有限公司

Henan Coreal Machinery Equipment Co., Ltd.



[www.corealmach.com](http://www.corealmach.com)



+86-15516601599



+86-0373-3021599



[louis@corealmach.com](mailto:louis@corealmach.com)



Building 3, Smart Logistics Ecological Technology Park,  
No. 99, South Outer Ring Road, High-tech Zone, Xinxiang  
City, Henan Province, China



**COREAL MACHINERY**